



OV-22-14



OV-D-22-14

Technické parametry

Médium	tlakový vzduch nemazaný
Pracovní tlak	3,5 – 7 bar
Pracovní teplota	5 – 50 °C
Pulsní frekvence	5 – 15 Hz
Hmotnost	73 g
Pneumatické připojení	vstup R 1/4 " / výstup G 1/4 "
Materiál	slitina hliníku / poniklovaná ocel

Rozměry

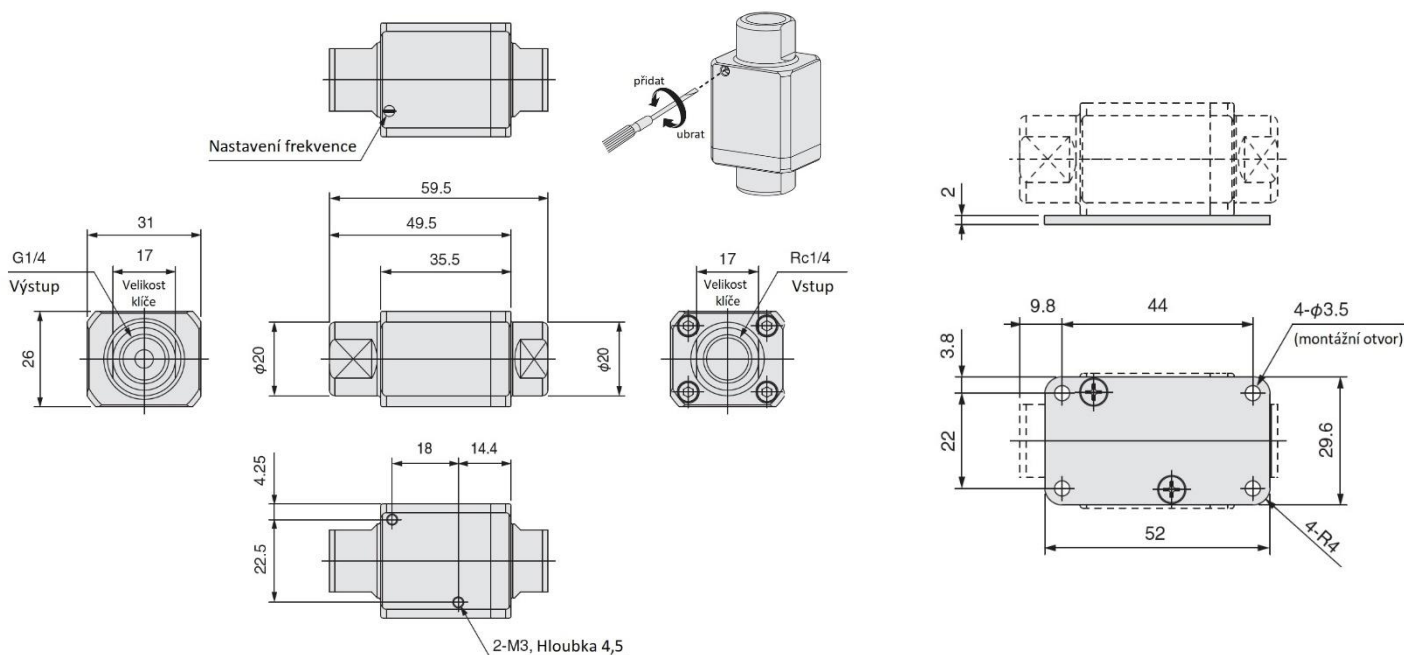

Charakteristiky

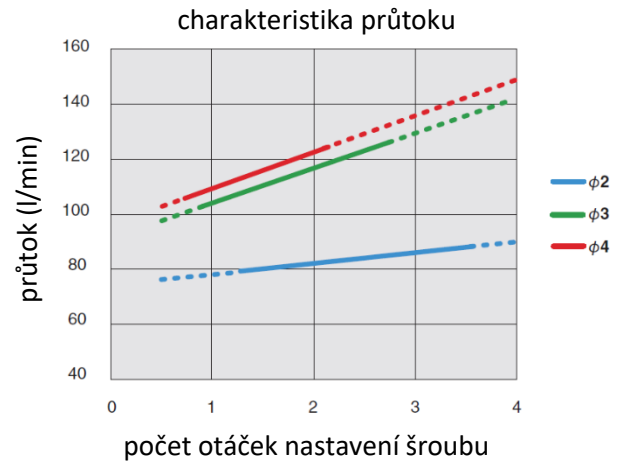
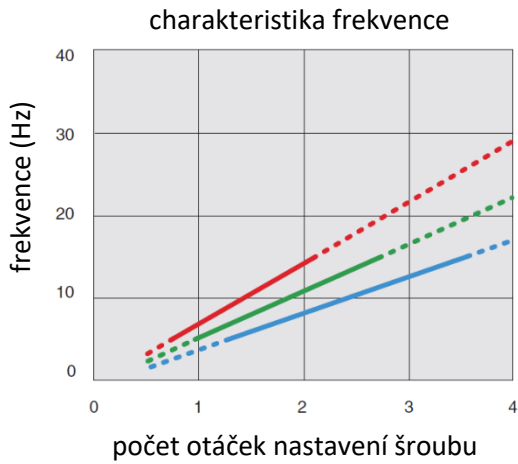

Výhody pulzního ofukování

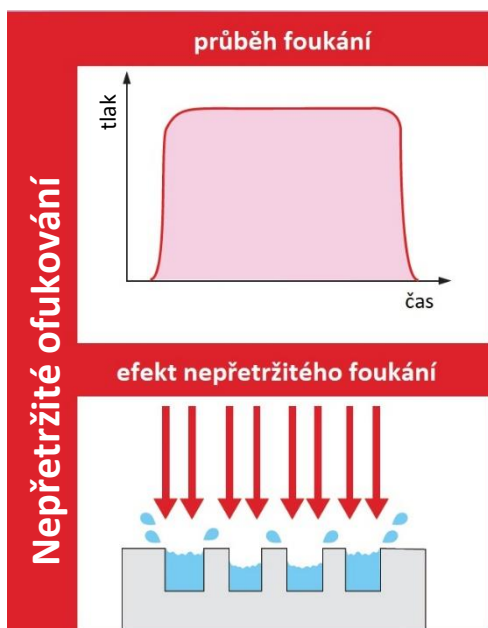

změna na
pulzní foukání

